

Overview

BACKGROUND

The City of Campbell River is reviewing opportunities to improve Alder Street to better balance vehicles, parking, pedestrians, cyclists, and public transit. The overall objective is to balance all travel modes while recognizing Alder Street's role as a key north-south road and providing access to adjacent single-family homes. Specifically, the corridor review will...

1. Ensure safe and efficient **vehicle** travel
2. Provide for sufficient **on-street parking**
3. Assess **sidewalks** to identify missing links and sidewalks in poor condition
4. Identify appropriate **bicycle** facilities
5. Ensure **public transit** is accommodated with improved bus stops
6. Opportunities for **traffic calming** and **boulevards** are considered

SUSTAINABLE OFFICIAL COMMUNITY PLAN (SOCP)

The Sustainable Official Community Plan (SOCP) provides the framework for future growth in Campbell River. The SOCP envisions the following:

*"...a transportation system that provides **safe, accessible, convenient, affordable** choices with emphasis on **high-quality walking, cycling, and transit options.**"*

MASTER TRANSPORTATION PLAN

The Master Transportation Plan was completed in 2012 and identifies Alder Street as one of five "major road enhancement" projects. The Master Transportation Plan provides specific guidance for Alder Street, as follows:

- Alder Street is classified as a "minor arterial" road intended to accommodate 5,000 to 15,000 vehicles per day and provide limited access to adjacent properties
- Signalization or a roundabout is recommended at 2nd Avenue and Merecroft Road
- Sidewalks (1.8m) are to be provided on both sides and prioritized near Pinecrest / Robron Park, as well as near the four schools and hospital
- A "marked wide curb lane" cycling facility is to be provided as a minimum 4.3 metre vehicle travel lane with a "sharrow" paint marking at the curb side to indicate the cyclist travel path
- Alder Street is identified as a "local transit network" along much of its length, consistent with the Transit Future Plan (2011)
- Trucks and dangerous goods will be discouraged on Alder Street

CONTACT

Drew Hadfield, Transportation Manager
City of Campbell River
t. 250.286.5783
e. transportation@campbellriver.ca

STUDY AREA



Issues / Opportunities



SIDEWALKS

Sidewalk widths vary and there are issues with utility poles (see above) and areas lacking sidewalks, particularly in the north portion of Alder Street.



ON-STREET PARKING

Parking is permitted on both sides along most of the corridor and occupancy rates are generally well below 50%. The road feels wide when on-parking is unoccupied and can promote vehicle speeding.



BUS STOPS

Certain bus stops along the corridor lack sidewalks, making them uncomfortable for average transit riders and hazardous to riders with mobility challenges or relying on mobility aids.



CYCLING ROUTES

Alder Street has steep slopes, particularly north of Simms Creek (pictured) and in the south. Other, flatter routes with less traffic to the west and east may be more attractive cycling options.



CURBS

Non-mountable curbs (left) are in-place along much of Alder Street. However mountable curbs (right) exist in much of the north portion and provide a limited physical barrier at the roadway edge, leading to inappropriate parking and potential for vehicles parking on adjacent sidewalks or boulevards.



SCHOOL ZONE

A rush of traffic, pick-ups/drop-offs, and students walking and cycling is experienced at Southgate Middle School at the beginning and end of each school day.

Parking

PARKING SUPPLY, NORTH END

North of Marina Blvd / Frances Rd

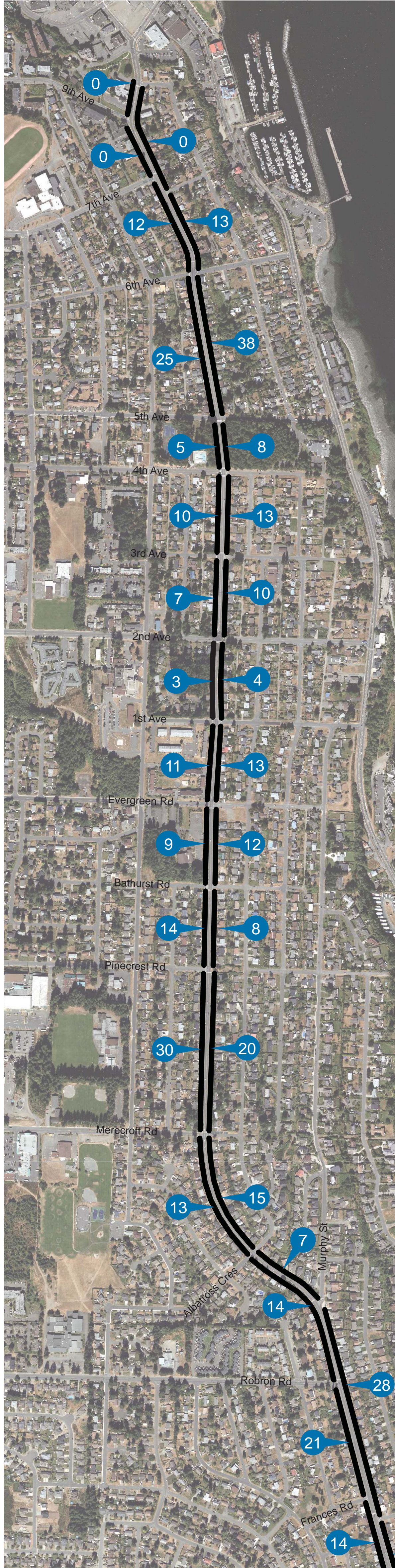

PARKING SUPPLY, SOUTH END

South of Marina Blvd / Frances Rd



LEGEND

Parking Supply, by block (approximate)

Estimated On-Street Parking Spaces on Alder Street...

850

Peak Hour On-Street Parking Occupancy Rate*

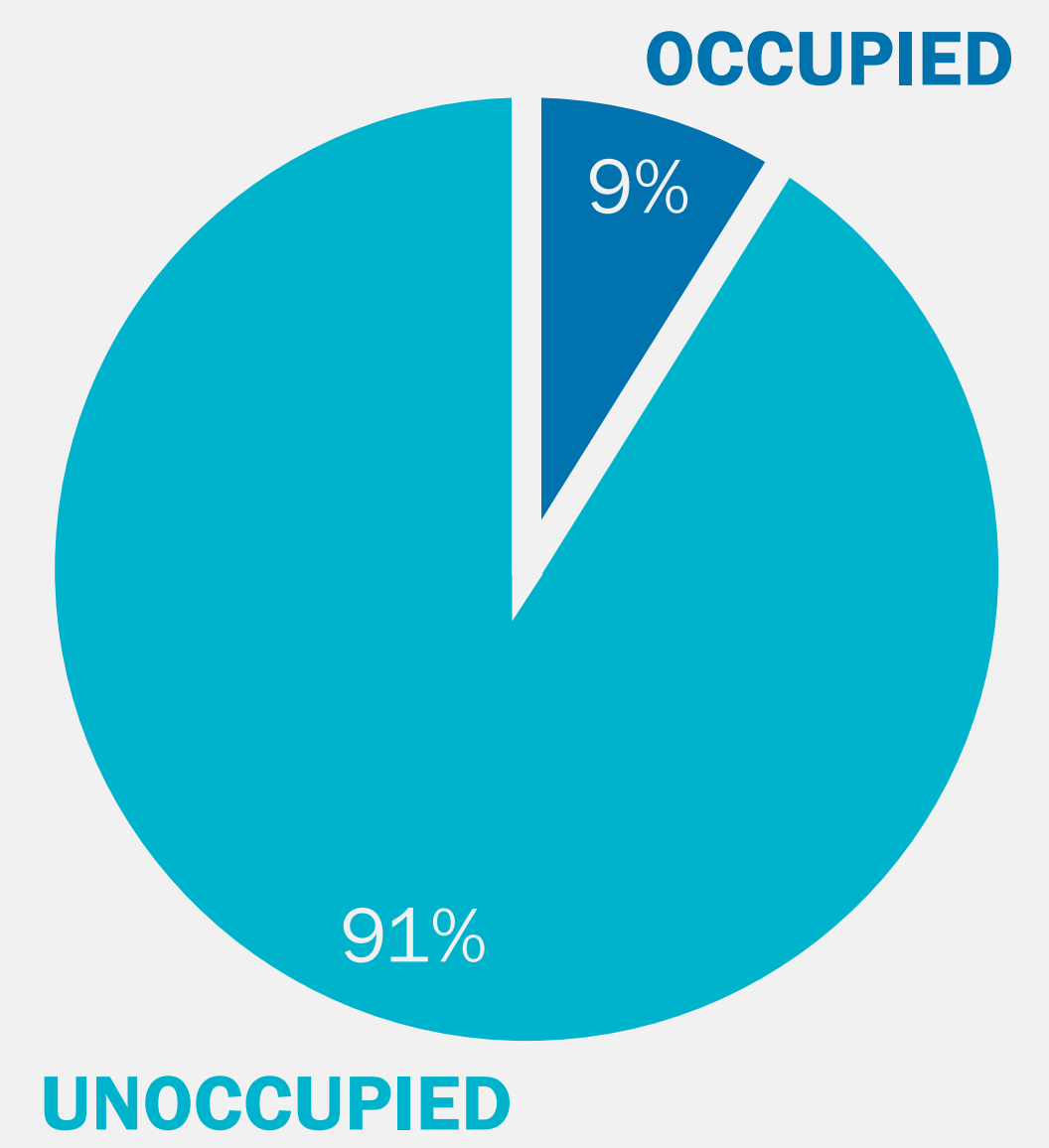

*based on observations from Wednesday, February 19 at 6pm and increased by 10% to reflect late evening and weekend demand

KEY FINDING

No on-street parking section exceeds 50% occupancy during peak periods, suggesting that on-street parking needs could be met on one side if road space is needed to accommodate sidewalks, cycling facilities or boulevards.



Sidewalks + Bus Stops

NORTH END

North of Marina Blvd / Frances Rd

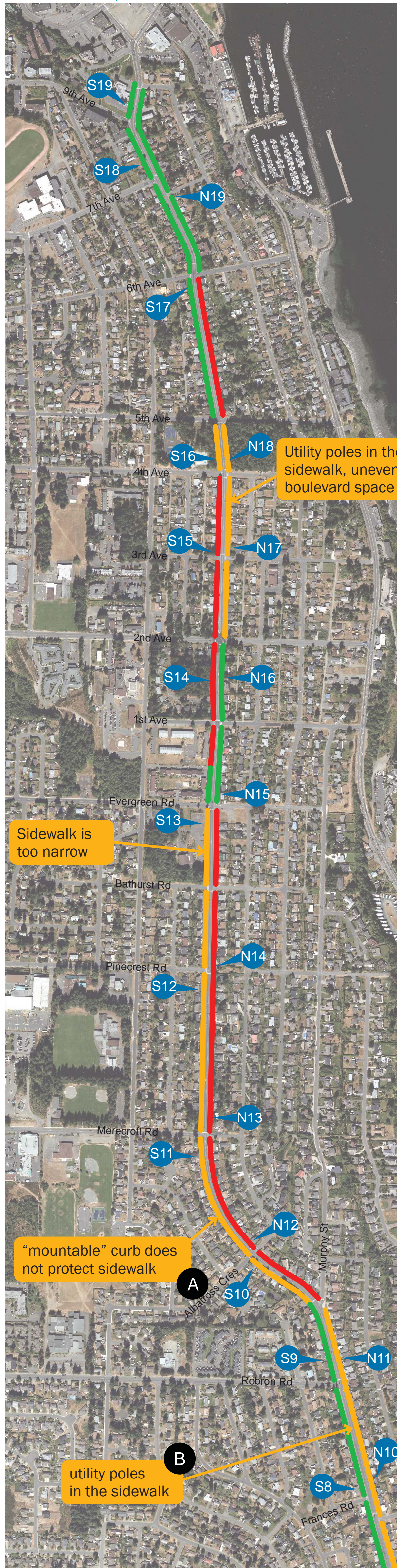

SOUTH END

South of Marina Blvd / Frances Rd



LEGEND

- **Adequate Sidewalk**
Sidewalk is at least 1.5m wide, has a "barrier" curb, and is not impeded by utility poles or other objects
- **Inadequate Sidewalk**
Sidewalk that is less than 1.5m wide, is adjacent a "mountable" curb, and/or is impeded by utility poles
- **No Sidewalk**
No sidewalk is provided
- **Bus Stop Location**



Sidewalks with "mountable" curbs do not provide a barrier between pedestrians and vehicles and may result in vehicles parked on the sidewalk.



Utility poles in the middle of the sidewalk make sidewalks uncomfortable for groups of pedestrians and unpassable for wheelchairs and most other mobility devices.

Cross-Section Options, north section

EXISTING

The north section is generally a 20.5m right-of-way with at least 11.5m from curb-to-curb. Sidewalk widths vary from 1.8m to 1.2m and are missing in certain areas. The roadway includes 5.8m (each direction) for vehicle traffic and parking.

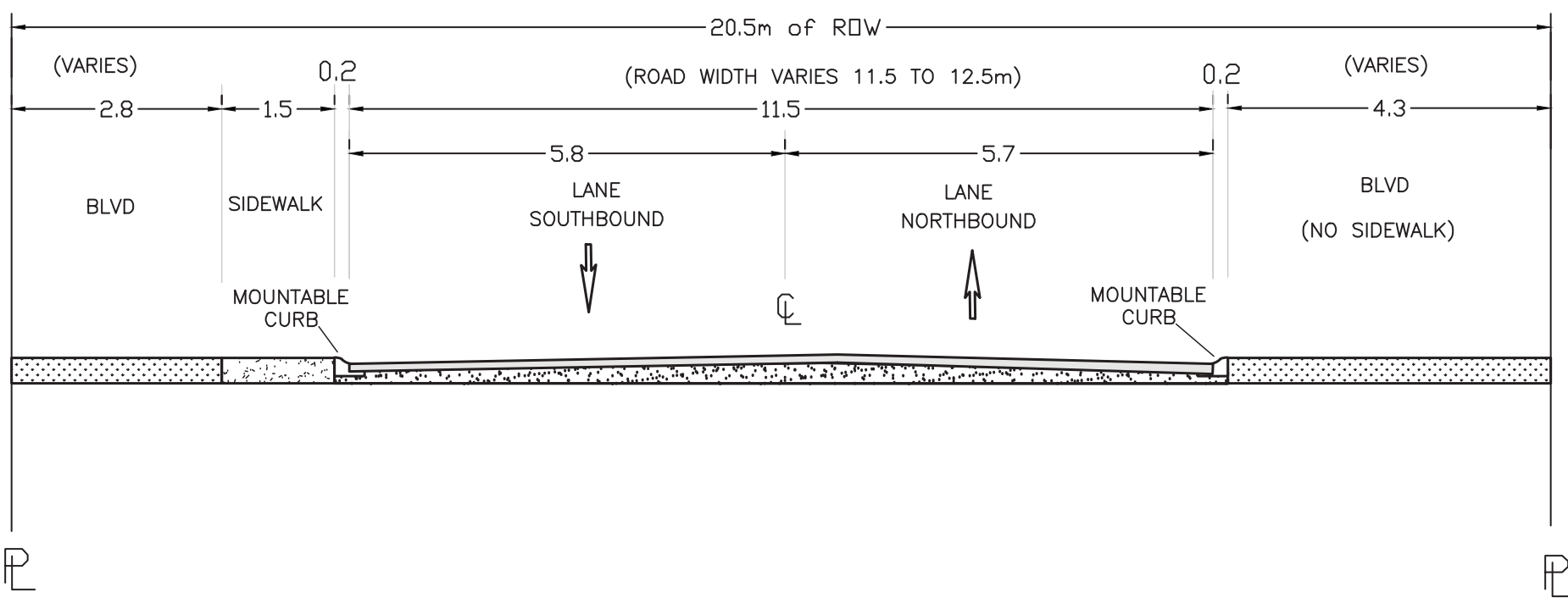

Option A: BIKE LANES

Advantages:

- Defined area for cyclists
- Clearly identifies the road as a cycling route
- Narrow vehicle lanes, slower vehicle speeds
- Low cost, uses existing curb-to-curb width

Disadvantages:

- Narrow lanes minimize the buffer between cyclists and drivers
- No boulevard between sidewalk and roadway
- Parking on one side of the street

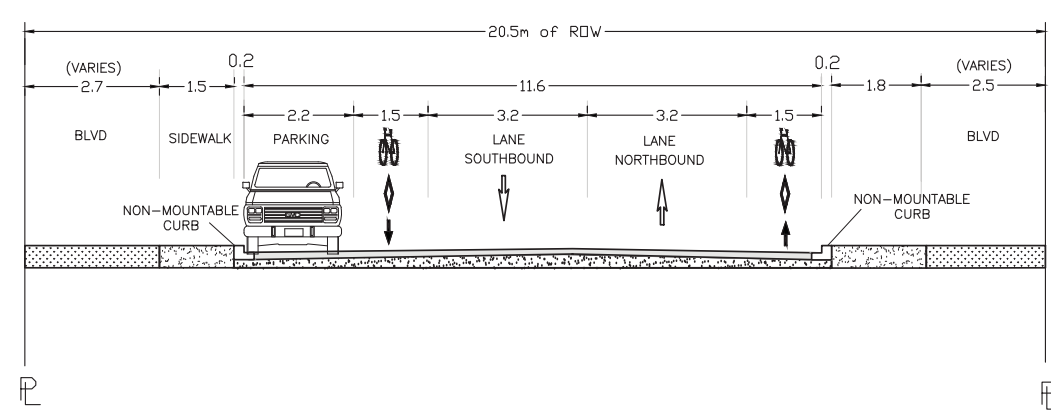
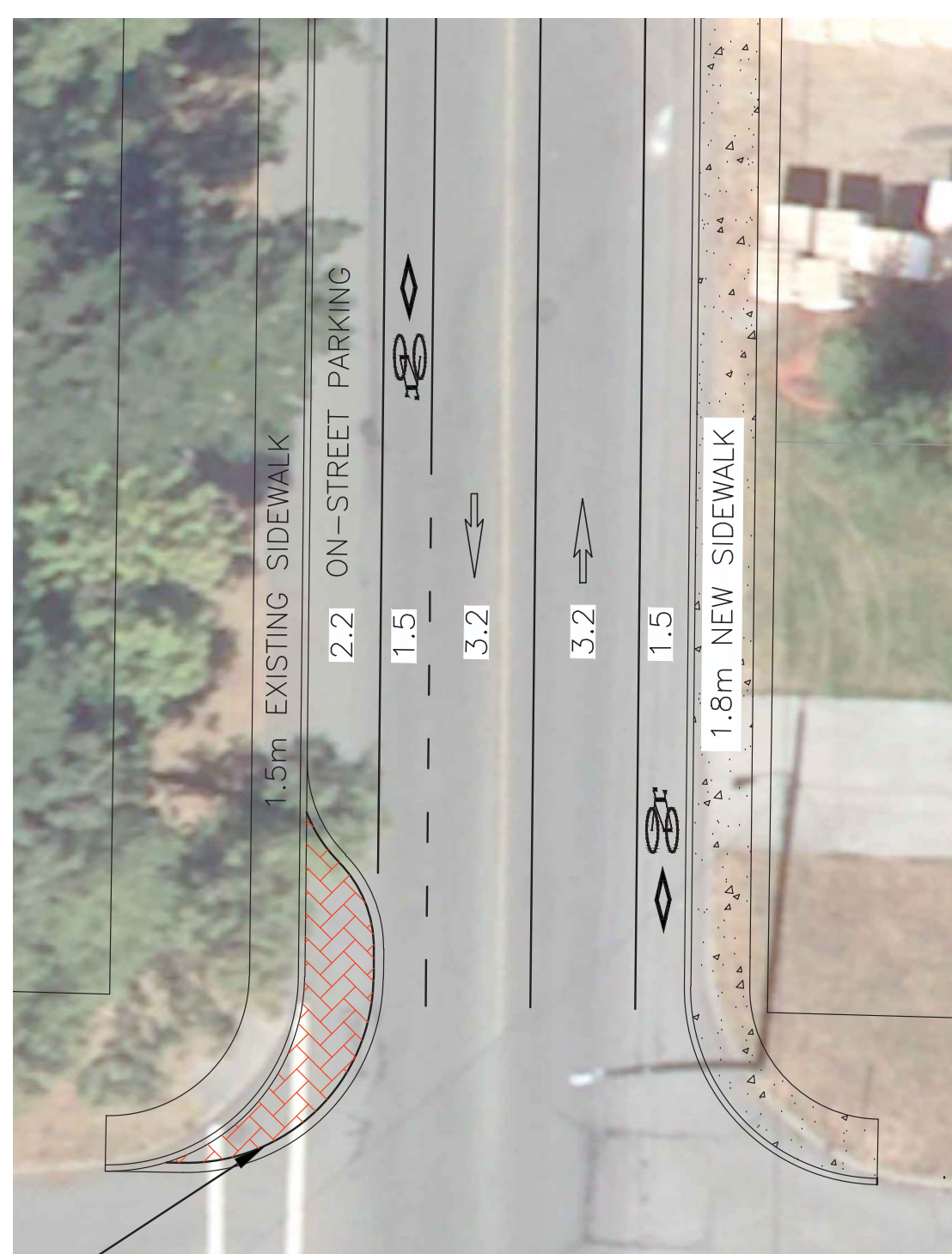

Option B: SHARED LANES, PARKING 1-SIDE

Advantages:

- Shared lanes facilitate cars, cyclists, and buses
- Wide parking area (one side of the road)
- Low cost, uses existing curb-to-curb width

Disadvantages:

- Not a continuously delineated cyclist area
- No boulevard between sidewalk and roadway
- Parking on one side of the street

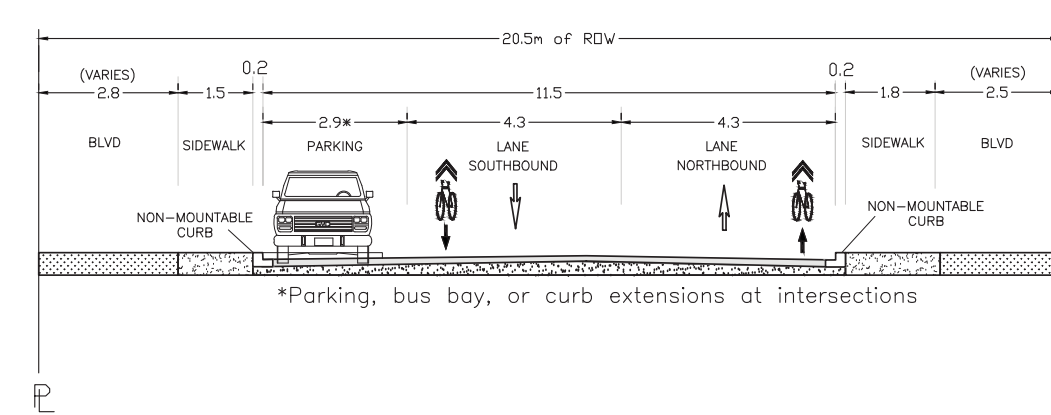

Option C: BOULEVARD, PARKING 1-SIDE, SHARED LANES

Advantages:

- Boulevard between roadway and sidewalk
- Shared lanes facilitate cars, cyclists, and buses
- Wide parking area (one side of the road)
- This option enhances all modes

Disadvantages:

- More costly; widening required and potential re-grading and/or retaining walls in many sections
- Not a continuously delineated cyclist area
- Parking on one side of the street

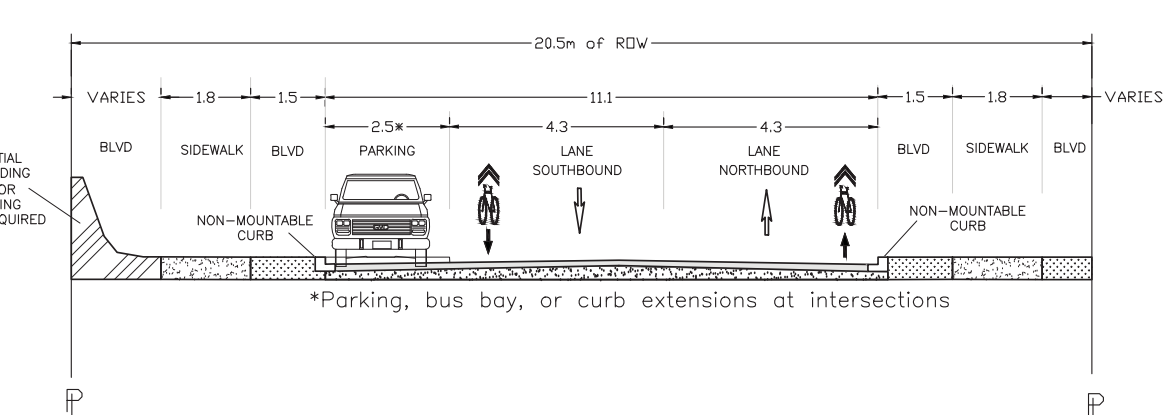
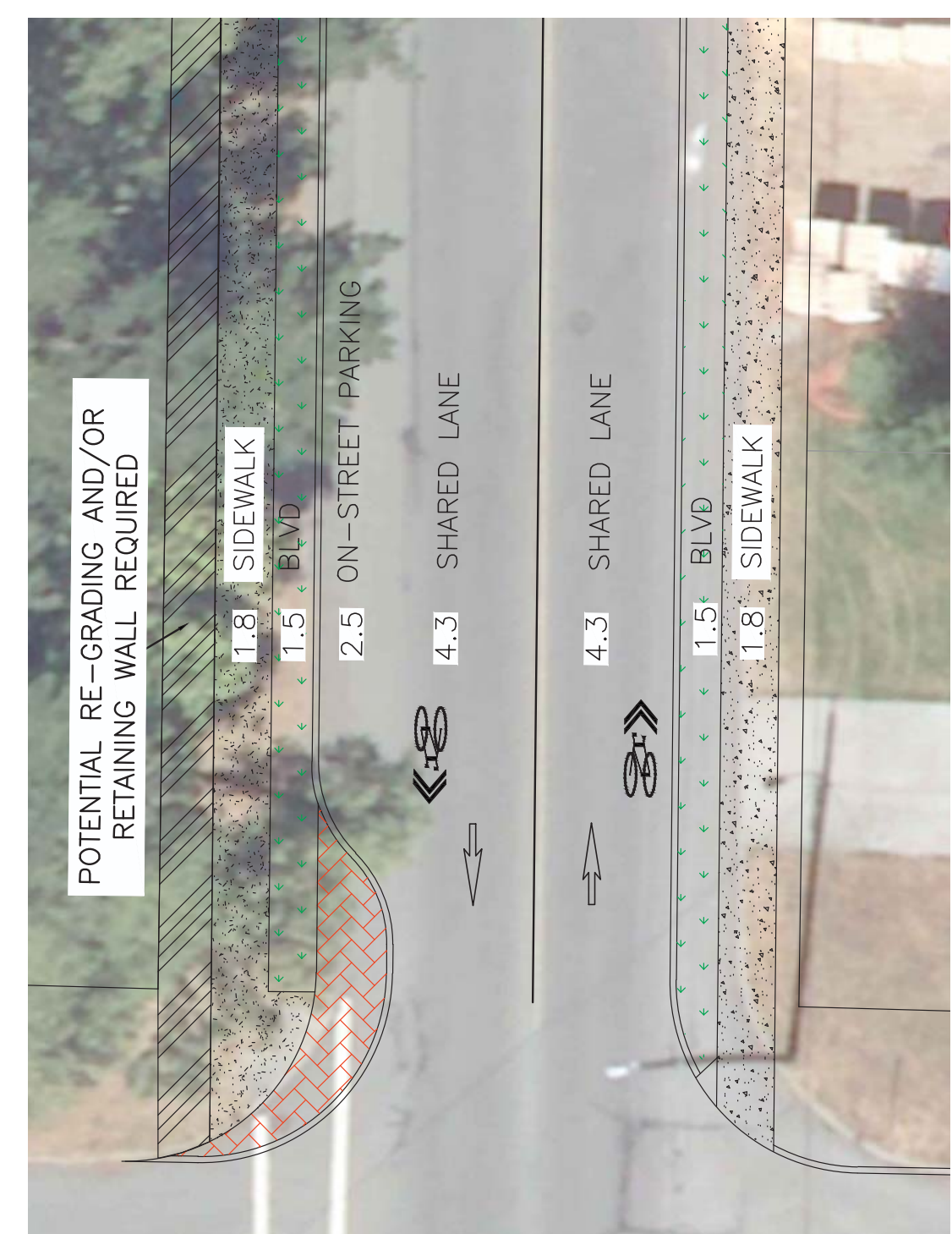

Cross-Section Options, south section

EXISTING

The south section is generally a 25m right-of-way with 13.7m from curb-to-curb. This section generally has 1.7m sidewalks on both sides and the roadway includes 6.8m (each direction) for vehicle traffic and parking.

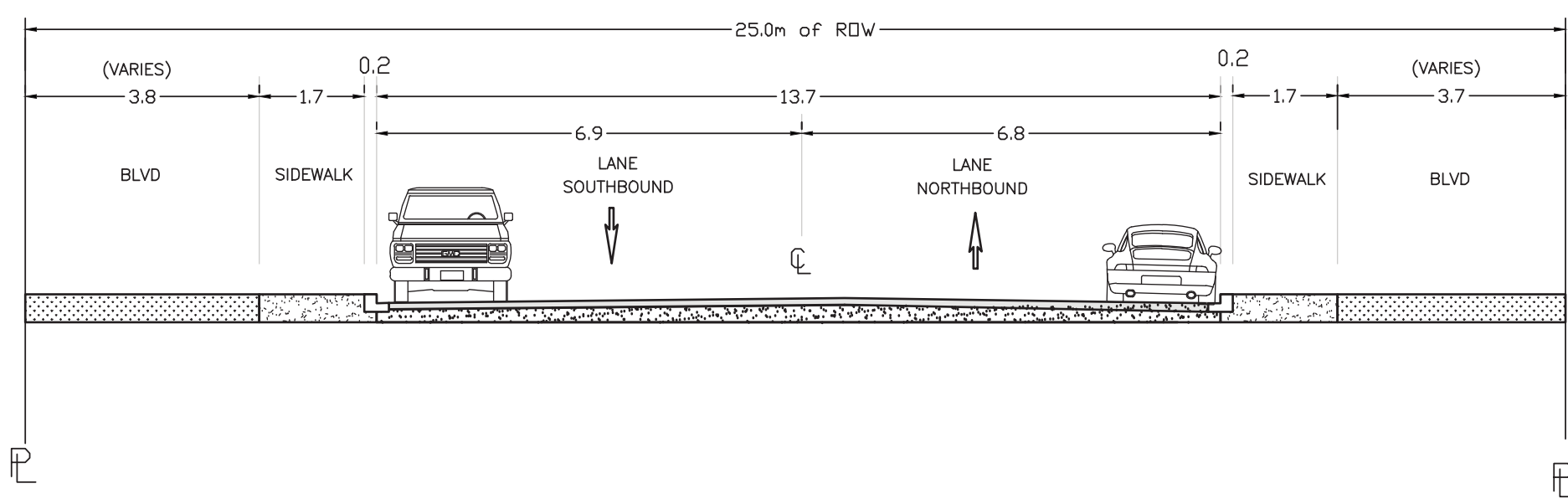

Option A: BIKE LANES

Advantages:

- Defined area for cyclists
- Clearly identifies the road as a cycling route
- Low cost, uses existing curb-to-curb width

Disadvantages:

- No boulevard between sidewalk and roadway
- Parking on one side of the street

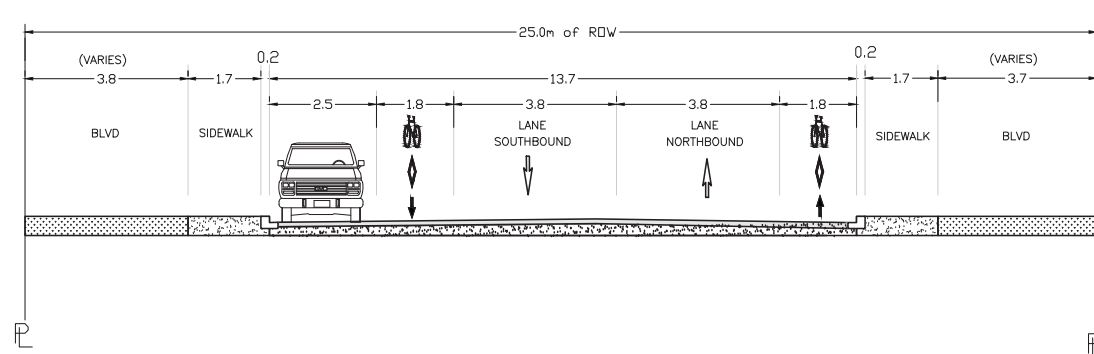
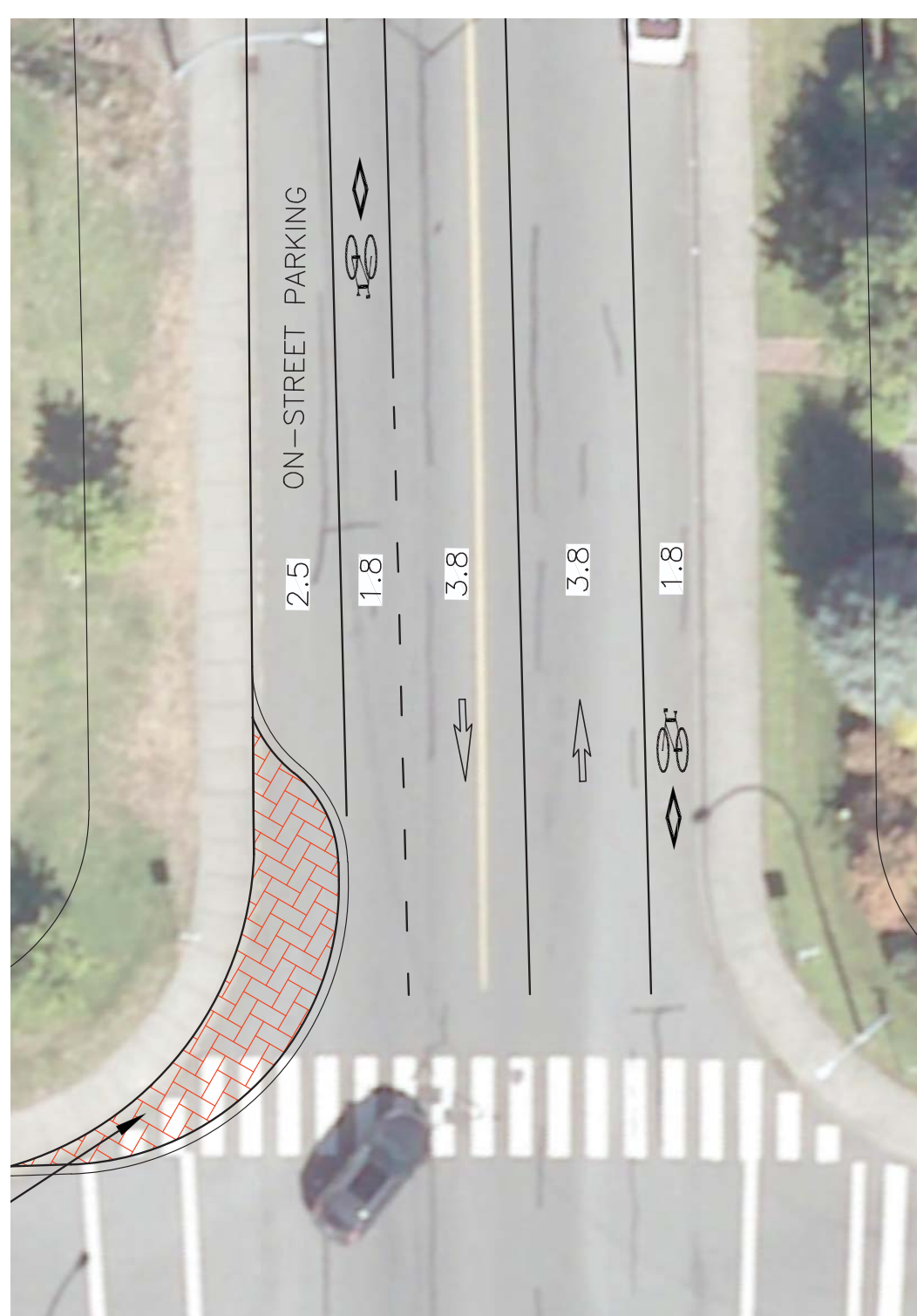

Option B: SHARED LANES, PARKING BOTH SIDES

Advantages:

- Shared lanes facilitate cars, cyclists, and buses
- Wide parking area (one side of the road)
- Low cost, uses existing curb-to-curb width

Disadvantages:

- Not a continuously delineated cyclist area
- No boulevard between sidewalk and roadway

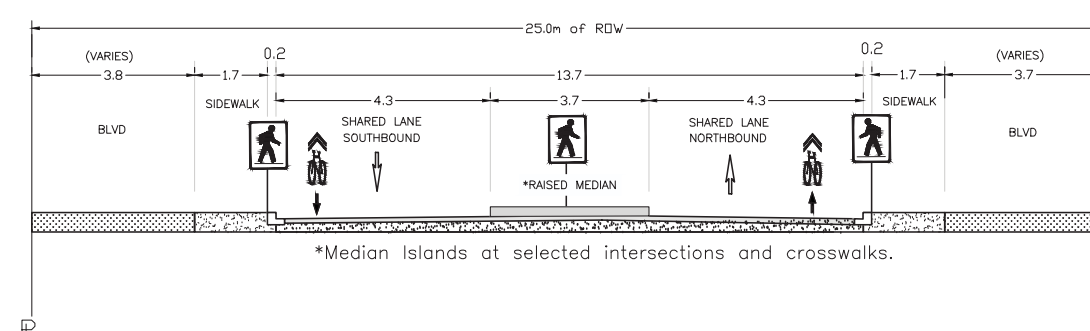
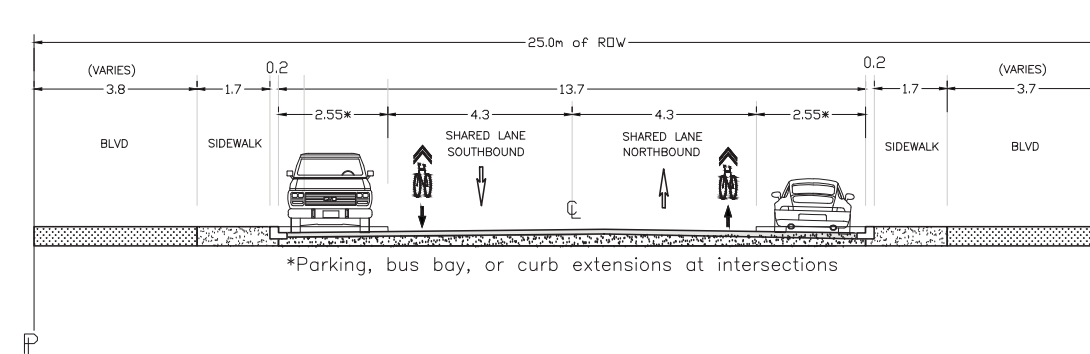
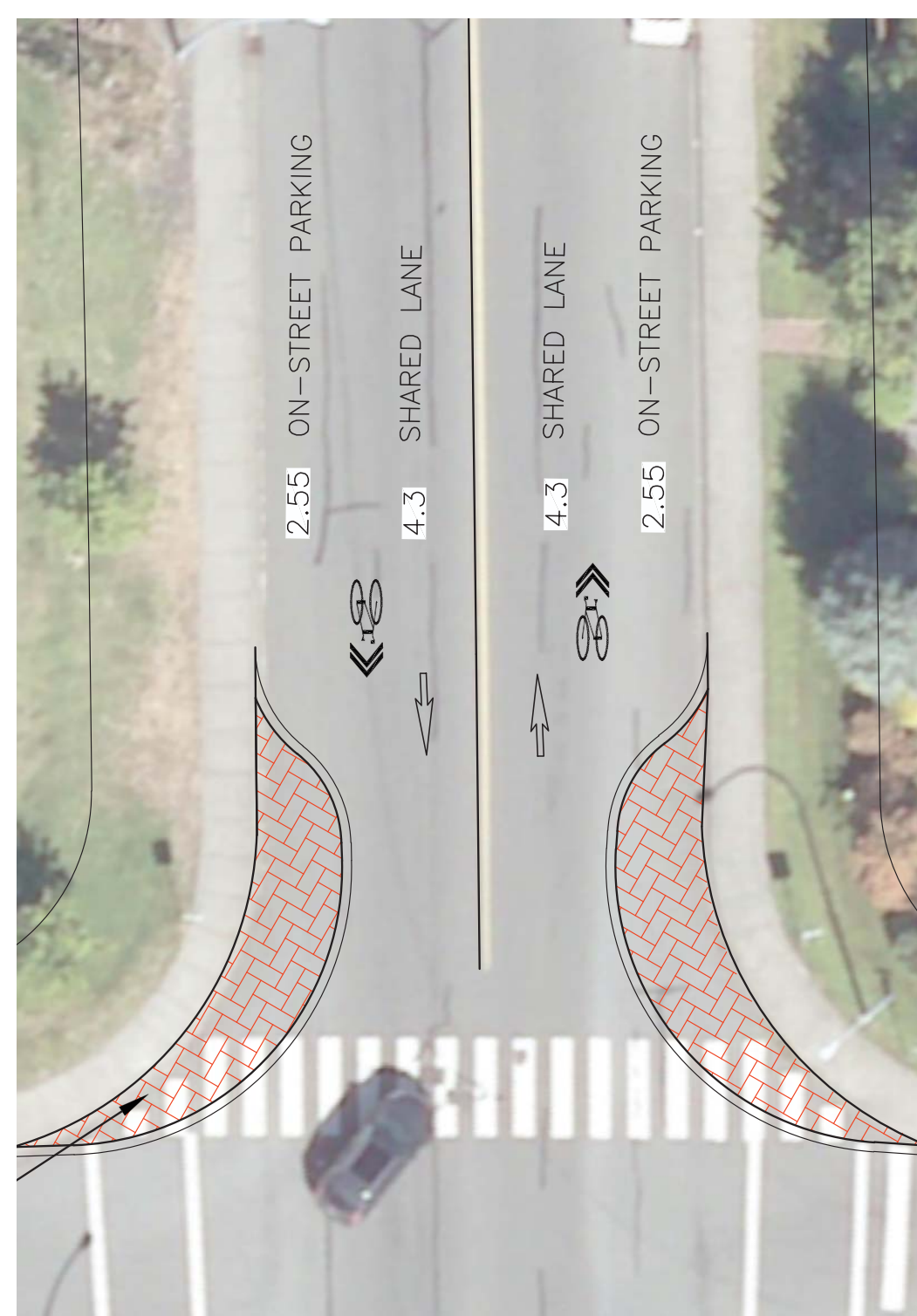

Option C: BOULEVARD, PARKING 1-SIDE, SHARED LANES

Advantages:

- Boulevard between road lanes and sidewalk
- Shared lanes facilitate cars, cyclists, and buses
- Wide parking area (one side of the road)
- This option enhances all modes

Disadvantages:

- Not a continuously delineated cyclist area
- Parking on one side of the street
- Higher cost due to curbs and drainage

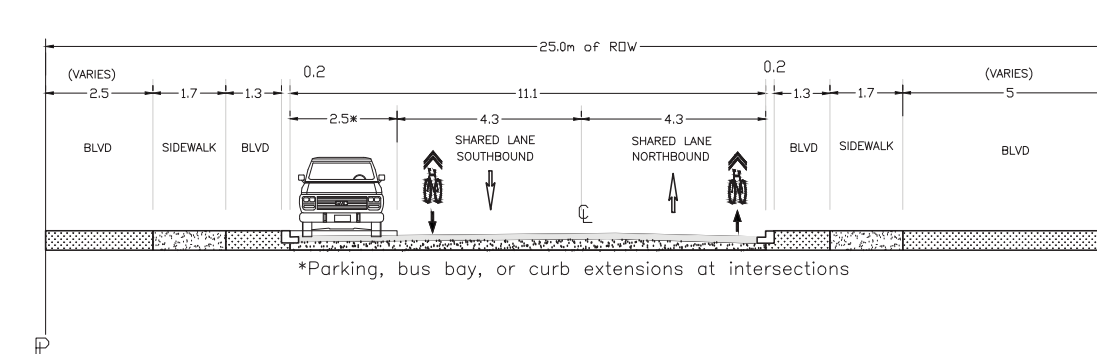
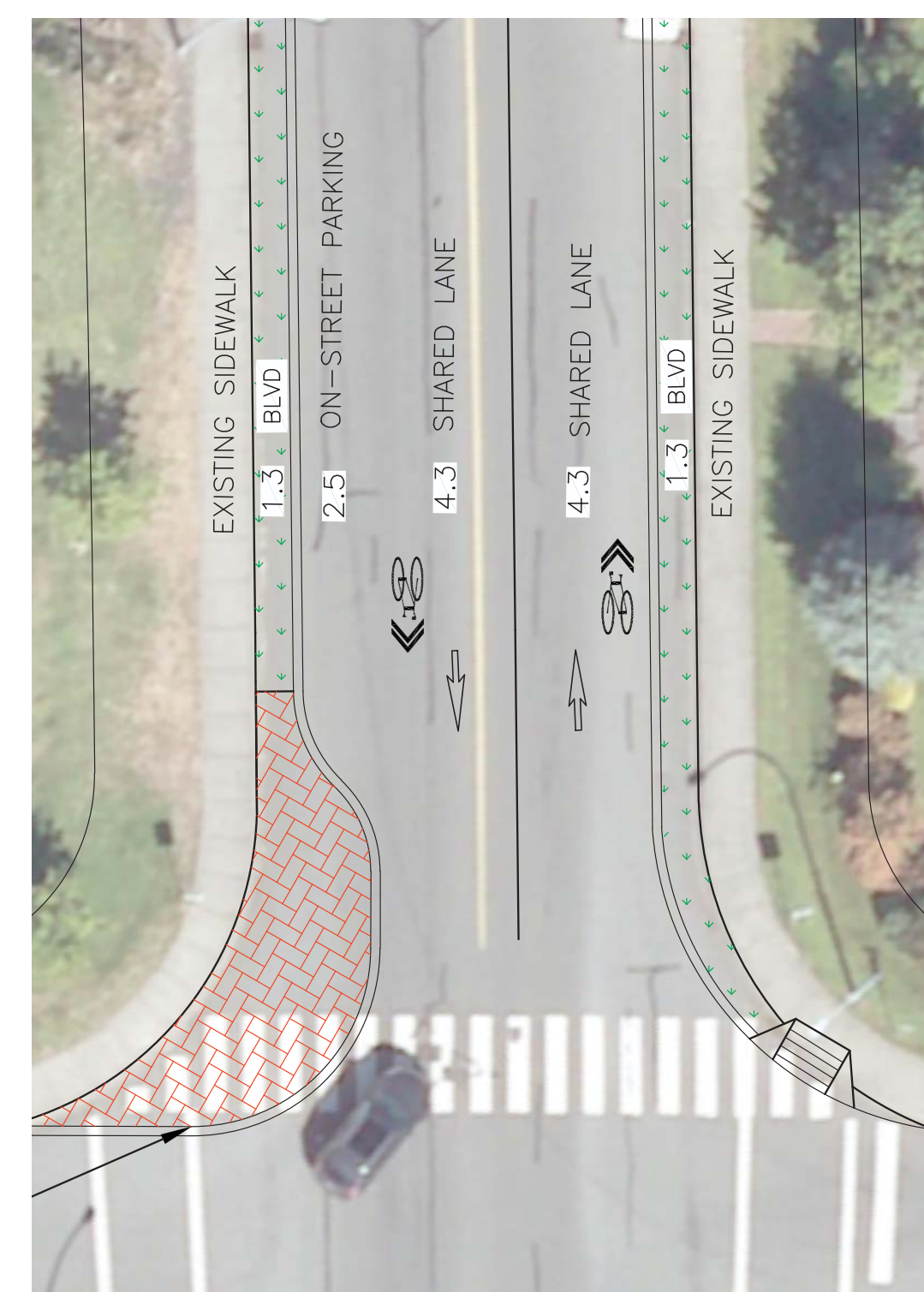

Design Options

TRAFFIC CALMING

Traffic calming may be installed at intersection to narrow the roadway and encourage slow driving. Consideration may be given to centre medians (top) and curb extensions (below), or both may be used in tandem with one another.

Centre Median



CYCLING FACILITIES

Alder Street is identified in the Master Transportation Plan as having a shared lane bicycle facility (ie. side-by-side with vehicles). Consideration may also be given to a bike lane.

Shared Lane (with "sharrow")



BOULEVARDS

Boulevards may be installed between the sidewalk and roadway to provide separation to increase pedestrian comfort and safety.



Curb Extensions



Bike Lane



BUS STOPS

Bus stops may be improved to include a sidewalk or concrete waiting area, shelter, benches, and rider information.



Next Steps

